

# C 15 WOOD LDX 55 S5

## TECHNOLOGY



## OPTIONAL



Potenza Globale Global Power Puissance globale Potencia global Verbrennungsleistung	Potenza Nominale Nominal Power Puissance Nominale Potencia Nominal Nennleistung	Rendimento totale total efficiency Rendement global Potencia global Gesamtausbeute	VOLUME riscaldabile heatable volume Volume chauffable Beheizbares Volumen Volumen calefactable	Consumo MAX Max consumption Consommation maximale Consumo maxi Maxi verbrauch	Portata Ventilatore Fan Range Débit du ventilateur Gebläse Förderleistung Caudal de ventilación	Uscita fumi Chimney Output Sortie conduit de cheminée Salida conducto de humos Rauchablass	Ingresso aria Air inlet Entrée air Lufteinlass	Uscite aria calda Warm air outlets Sorties d'air chaud Warmluftausgänge Salidas de aire caliente	Peso Weight Poids Peso Gewicht	Camera di combustione Burnig chamber Chambre de combustion Camera de combustion Brennraum
<b>18,1</b>	<b>14,5</b>	<b>80,1</b>	<b>430</b>	<b>3,9</b>	<b>400</b>	<b>202</b>	<b>120</b>	<b>2</b>	<b>245</b>	<b>660x450</b>

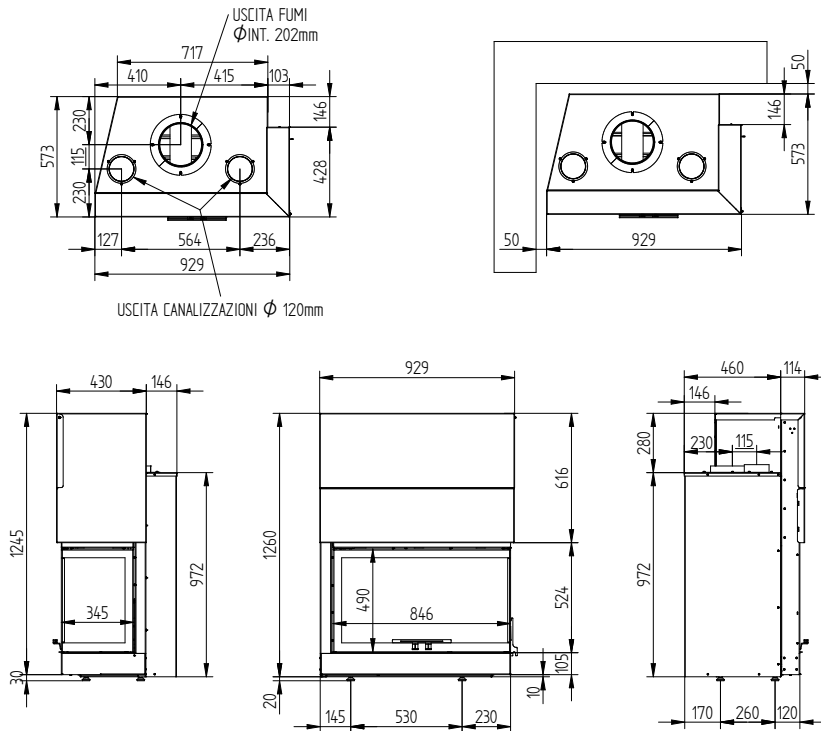

## CODE DESCRIPTION

C15WLDX55S5 C 15 WOOD LDX 55

### OPTIONAL

MORKV  
DFL60BK  
DFL60WH  
CVO  
KSF  
MOFOOT

VENTILATION KIT  
BLACK LINEAR DIFFUSER  
WHITE LINEAR DIFFUSER  
HORIZONTAL AIR CONVEYER  
PAIR OF MOUNTING BRACKETS KIT  
SUPPORT BASE