



# VALVOLA A SFERA BALL VALVE

## Art.1692

### Descrizione / Description

Valvola a sfera in ottone (CW617N) con leva a farfalla rossa con estremita' a pressare per tubo multistrato e dado folle.

Ball valve made of brass (CW617N) with red "T" handle with press multilayer pipes end and loose nut.

### Funzione / Function

Le valvole Serie 1692 si adattano ad ogni tipo di impianto idraulico domestico e commerciale, applicazioni industriali ed agricole, impianti di riscaldamento ed igienico sanitari, olii vari, prodotti petroliferi e generalmente con ogni fluido non corrosivo.

The valves Series 1692 are suitable for domestic and commercial plumbing, industrial and agricultural application, heating and sanitary systems, pneumatic systems, generally with every fluid with water based.



### Caratteristiche Tecniche

Temperatura max di esercizio: 95 °C  
 Temperatura min di esercizio: -20°C (\*)  
 Pressione max di esercizio: 10 bar (relativo al tubo multistrato)

### Technical Features

Maximum temperature: 95°C  
 Minimum temperature: -20°C (\*)  
 Maximum operating pressure: 10 bar (referred to multilayer pipe)

(\*) purché il fluido rimanga in fase liquida / provided that the fluid remains in the liquid phase

### Dimensioni Dimensions

Ø	16	20	25	26	32
Size	3/4"	3/4"	3/4"	3/4"	1"
A	50	50	50	50	50
L	47	47	47	47	47
L1	41	41	41	41	41

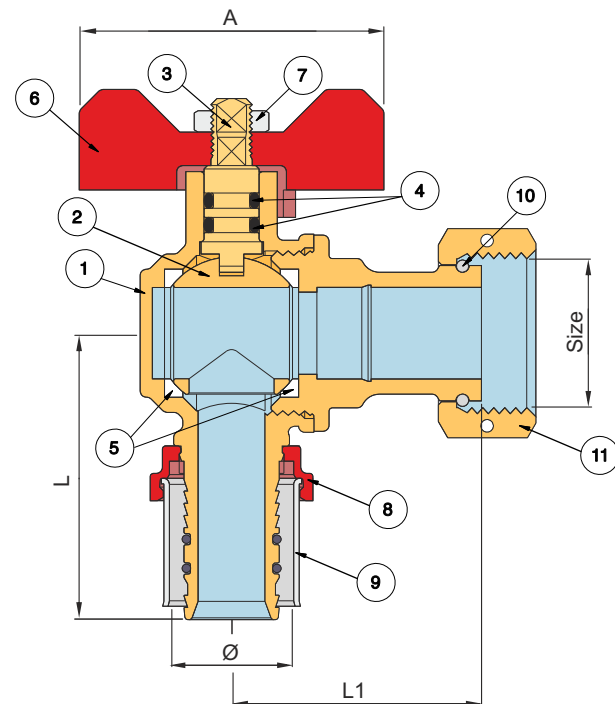

Descrizione	Materiale	Trattamento	Description	Material	Treatment
① Corpo	Ottone CW617N - EN12165	-	① Body	CW617N-EN12165 brass	-
② Sfera	Ottone CW617N - EN12164	Cromato	② Ball	CW617N-EN12164 brass	Chromium plated
③ Stelo	Ottone CW617N - EN12164	-	③ Stem	CW617N-EN12164 brass	-
④ O-rings	Gomma etilene-propilene EPDM	-	④ O-rings	Nitrile Rubber NBR	-
⑤ Guarnizioni laterali	P.T.F.E.	-	⑤ Side washers	P.T.F.E.	-
⑥ Leva e farfalla	Alluminio	Verniciato	⑥ Handle	Aluminium	Painted
⑦ Dado	Acciaio	Zincato	⑦ Nut	Steel	Zinc plated
⑧ Ghiera	Nylon PA 0,6	-	⑧ Sleeve lock ring	Nylon PA 0,6	-
⑨ Bussola	Acciaio Inox AISI 304	-	⑨ Sleeve	Stainless steel AISI 304	-
⑩ Anellino	Acciaio Inox AISI 302	-	⑩ Ring	Stainless steel AISI 302	-
⑪ Girello	Ottone CW617N - EN12165	-	⑪ Loose nut	CW617N-EN12165 brass	-

### Certificazioni Certifications





## Istruzioni per il corretto montaggio :

Il taglio del tubo deve essere eseguito con attrezzature idonee ad ottenere un taglio senza bave e perfettamente perpendicolare all' asse del tubo.

L' estremità tagliata deve inoltre essere sbavata utilizzando l' utensile calibratore/sbavatore Art. 1498.

Calzare il tubo sul portagomma e eseguire la pressatura della valvola utilizzando la pressatrice (Art. 1685-1686) e la pinza modello "TH" personalizzata Tiemme nella misura idonea per il tubo in uso.

## Instruction for the correct assembly :

The pipe cut shall be done with appropriate toolings in order to obtain a precise and perpendicular cut without any trimming. The pipe end shall be cleaned using the deburring tool Art. 1498. Fit the pipe on the valve and press it using the crimping machine (Art. 1685-1686) and the tong "TH" model personalized Tiemme for the specific size of the pipe in use.

## Istruzioni per l' installazione

Le valvole possono essere montate in qualsiasi posizione (orizzontale, verticale, ...) purchè siano visibili, accessibili e le operazioni di manovra possano essere facilmente eseguite fino alla completa chiusura e/o apertura.

Salvo diversamente indicato la chiusura della valvola avviene in senso orario e l' apertura in senso anti-orario.

La direzione di montaggio della valvola rispetto al flusso del circuito è indifferente se non diversamente specificato con l' apposizione di specifiche marcature (generalmente frecce) sul corpo valvola.

L' impianto deve essere progettato e realizzato in modo tale da evitare sollecitazioni tali da danneggiare la valvola ed impedirne la corretta tenuta ed il buon funzionamento.

Le operazioni di collegamento tra la valvola e la raccorderia di connessione all' impianto devono essere eseguite con attrezzature idonee. La coppia di serraggio deve essere tale da garantire la corretta tenuta senza arrecare danneggiamenti alla valvola od ai raccordi.

Ad installazione completata è necessario eseguire la verifica delle tenute secondo quanto specificato dalle norme tecniche e/o dalle leggi vigenti nel paese di utilizzo.

La valvola non va tenuta in posizione intermedia per lunghi periodi onde evitare danneggiamenti degli organi di tenuta della valvola stessa.

In caso di lunga inattività della valvola è possibile che la manovrabilità risulti difficile pertanto si rende necessario l' utilizzo di "leve lunghe" per facilitarne l' apertura e/o chiusura.

Per mantenere la valvola ed i relativi organi di tenuta in buone condizioni e suggerito installare un filtro per la raccolta di eventuali impurità a monte della valvola.

Tiemme Raccorderie SpA declina ogni responsabilità in caso di guasti e/o incidenti qualora l' installazione non sia stata realizzata in conformità con le norme tecniche e scientifiche in vigore ed in conformità a manuali, cataloghi e/o relative disposizioni tecniche indicate da Tiemme Raccorderie SpA.

Per qualsiasi ulteriore informazioni rivolgersi ai rivenditori autorizzati o direttamente a TIEMME SpA.

## Installation instructions

The valves can be installed in any position (horizontal, vertical, ...) provided that shall be placed in visible and accessible position and the open/close operations shall be easily and completely done.

Otherwise stated to close the valve the handle shall be turned clockwise, counterclockwise to open it.

Otherwise stated by specific marks on the valve body (arrows,...) there is no valve flow direction.

The system shall be designed and realised in order to avoid any stress that could damage the valve and could compromise the sealing and the correct working of the valve.

All installation operations shall be done using properly tooling. The tightenings shall be such as to guarantee the sealing but without make any damage to the valve or fittings.

Once the installation have been completed is necessary to verify the sealings according to technical specifications and/or what required by the country of installation.

The valve should not be kept in intermediate position for a long period of time in order to avoid any damages of the valve sealings.

If the valve have not been used for a long period of time it may be difficult to operate therefore it will be necessary to use a "long lever".

To kept the valve and sealings in good conditions it is suggested to place a filter upstream in order to stop impurity.

Tiemme Raccorderie SpA decline any responsibility in case of damages and/or accidents when the installation is not done in conformity with technical and scientific rules in force and in conformity with manuals, catalogues and/or technical documentation written by Tiemme Raccorderie SpA.

For any further information please refer to your local dealer or directly to TIEMME S.p.A.

## Accessori (vedere il catalogo per ulteriori dettagli)

### Accessories (see catalogue for further details)

Art. 1681



Pinze "TM" per pressature  
"TM" pressing tongs

Art. 1695TM01



Pressatrice a batteria  
Battery crimping machine

Art. 1695TM01S



Pressatrice a batteria  
Battery crimping machine

Art. 1695TM01A



Adattatore di rete 230 Vac  
230Vac adaptor suitable

Art. 1695TM01B



Batteria per pressatrice  
Battery for crimping machine

Art. 1695TM01C



Caricabatteria per art. 1695TM01B  
Battery charger for art. 1695TM01B



Valigetta con set calibratori/sbavatori Ø14-Ø40  
Box with deburring tools set Ø14-Ø40

Art. 1498UM



Calibratori/sbavatori con impugnatura fissa  
(disponibili nelle misure Ø16-Ø32)  
Deburring tools with fixed handle  
(available on size Ø16-Ø32)

Art. 1498US



Utensili calibratore/sbavatore intercambiabili  
per utilizzo con trapano o articolo 1498MT  
(disponibili nelle misure Ø14-Ø32)  
Interchangeable deburring tools to be used  
with drill machine or article 1498MT  
(available on size Ø14-Ø32)

Art. 1498IT



Impugnatura a "T" intercambiabile  
(per utilizzo con articolo 1498US)  
Interchangeable "T" handle  
(to be used with article 1498US)

Art. 1481



Staffa per curve flangiate Art. 1406  
Bracket for wallplate elbow Art. 1406

**TIEMME Raccorderie S.p.A.**  
Via Cavallera 6/A (Loc. Barco) - 25045 Castegnato (Bs) - Italy  
Tel +39 030 2142211 R.A. - Fax +39 030 2142206  
info@tiemme.com - www.tiemme.com

TIEMME Raccorderie S.p.A. si riserva di apportare modifiche in qualsiasi momento senza preavviso. È vietata qualsiasi forma di riproduzione, se non autorizzata.  
TIEMME Raccorderie S.p.A. reserves the right to modify contents in any time without prior advise. Is forbidden any reproduction unless under TIEMME authorization